

For New Technology Network

NTN®

NTNcorporation

Spherical Plain Bearings

CAT. No. 5301-II / E



Warranty

NTN warrants, to the original purchaser only, that the delivered product which is the subject of this sale (a) will conform to drawings and specifications mutually established in writing as applicable to the contract, and (b) be free from defects in material or fabrication. The duration of this warranty is one year from date of delivery. If the buyer discovers within this period a failure of the product to conform to drawings or specifications, or a defect in material or fabrication, it must promptly notify NTN in writing. In no event shall such notification be received by NTN later than 13 months from the date of delivery. Within a reasonable time after such notification, NTN will, at its option, (a) correct any failure of the product to conform to drawings, specifications or any defect in material or workmanship, with either replacement or repair of the product, or (b) refund, in part or in whole, the purchase price. Such replacement and repair, excluding charges for labor, is at NTN's expense. All warranty service will be performed at service centers designated by NTN. These remedies are the purchaser's exclusive remedies for breach of warranty.

NTN does not warrant (a) any product, components or parts not manufactured by NTN, (b) defects caused by failure to provide a suitable installation environment for the product, (c) damage caused by use of the product for purposes other than those for which it was designed, (d) damage caused by disasters such as fire, flood, wind, and lightning, (e) damage caused by unauthorized attachments or modification, (f) damage during shipment, or (g) any other abuse or misuse by the purchaser.

THE FOREGOING WARRANTIES ARE IN LIEU OF ALL OTHER WARRANTIES, EXPRESS OR IMPLIED, INCLUDING BUT NOT LIMITED TO THE IMPLIED WARRANTIES OF MERCHANTABILITY AND FITNESS FOR A PARTICULAR PURPOSE.

In no case shall NTN be liable for any special, incidental, or consequential damages based upon breach of warranty, breach of contract, negligence, strict tort, or any other legal theory, and in no case shall total liability of NTN exceed the purchase price of the part upon which such liability is based. Such damages include, but are not limited to, loss of profits, loss of savings or revenue, loss of use of the product or any associated equipment, cost of capital, cost of any substitute equipment, facilities or services, downtime, the claims of third parties including customers, and injury to property. Some states do not allow limits on warranties, or on remedies for breach in certain transactions. In such states, the limits in this paragraph and in paragraph (2) shall apply to the extent allowable under case law and statutes in such states.

Any action for breach of warranty or any other legal theory must be commenced within 15 months following delivery of the goods.

Unless modified in a writing signed by both parties, this agreement is understood to be the complete and exclusive agreement between the parties, superceding all prior agreements, oral or written, and all other communications between the parties relating to the subject matter of this agreement. No employee of NTN or any other party is authorized to make any warranty in addition to those made in this agreement.

This agreement allocates the risks of product failure between NTN and the purchaser. This allocation is recognized by both parties and is reflected in the price of the goods. The purchaser acknowledges that it has read this agreement, understands it, and is bound by its terms.

© NTN Corporation. 2000

Although care has been taken to assure the accuracy of the data compiled in this catalog, NTN does not assume any liability to any company or person for errors or omissions.

NTN SPHERICAL PLAIN BEARINGS



NTN SPHERICAL PLAIN BEARINGS

CONTENTS

TECHNICAL DATA

1. Types of Spherical Plain Bearings	3
2. Tolerances of Spherical Plain Bearings	4
3. Loads Acting on Spherical Plain Bearings	6
4. Selection of Spherical Plain Bearings	7
5. Life of Spherical Plain Bearings	9
6. Recommended Fit and Internal Clearance	11
7. Cautions to Installation	12

BEARING TABLES

Spherical Plain Bearings

Self-lubricating type

Series SAR1/SAR1••SS	13
Series SAR4	14
Series SAR2 (Inch size)	15

Lubricating type

Series SA1/SA1••SS	16
Series SA4	18
Series SA2 (Inch size)	20

Thrust Spherical Plain Bearings

Lubricating type

Series SAT	22
------------	----



Spherical plain bearings are used in equipment that undergo articulated movement, involving oscillating or aligning motions.

NTN spherical plain bearings are classified broadly into the self-lubricating type with a solid PTFE based liner and the lubrication type in which contact between the inner and outer rings is metal-to-metal.

1. Types of Spherical Plain Bearings

1.1 Self-lubricating type spherical plain bearings

Self-lubricating spherical plain bearings are primarily intended for situations where a long life, free from maintenance and lubrication requirements, is desired. They are also used in parts of machines where lubrication would be difficult.

In the NTN self-lubricating spherical plain bearing a self-lubricating PTFE based liner is securely bonded to the outer ring.

Therefore, lubrication, maintenance and inspection are necessary. As there is no oil staining, the bearing is always clean.

It is particularly suitable where the load works in one direction only or where there is a low frequency of oscillating movement.

The inner ring is made of high carbon chromium bearing steel and its sliding surface is hard chromium plated.

Where higher pressures are involved, a special type of spherical plain bearing with a steel mesh reinforced liner is available. Please contact NTN for details of this item.

The following types of NTN spherical plain bearings are available:

- SAR 1 Series : Equivalent to ISO "E" series
- SAR 1 · · SS Series : Equivalent to ISO "E" series, with seal
- SAR 2 Series : Inch series
- SAR 4 Series : Special dimension series

All of these types are suitable for a temperature range of -50°C (-58°F) to $+100^{\circ}\text{C}$ ($+212^{\circ}\text{F}$).

1.2 Lubrication type spherical plain bearings

Lubrication type spherical plain bearings feature sliding surfaces where both the inner and outer rings are steel. The outer ring has a single fracture for assembly. The absence of a fitting groove greatly increases the strength of the bearing.

These bearings are particularly suited for subjection to impact loads or alternating loads.

Both the inner and outer rings are manufactured from high carbon chromium bearing steel. After heat treatment and grinding, their surfaces are treated with a phosphate film, which renders them highly resistant to rust. Furthermore, their sliding surfaces are coated with molybdenum disulfide, which provides very effective lubrication of the bearing in its initial stage of operation. Both the inner and outer rings are provided with an oil hole, so that oil can be inserted either from the shaft or from the housing.

The NTN lubrication type spherical plain bearing comes in the following types;

- SA 1 Series : Equivalent to ISO "E" series
- SA 1 · · SS Series : Equivalent to ISO "E" series, with seal
- SA 2 Series : Inch series
- SA 4 Series : Special dimensions series
- SAT Series : Thrust type series

The temperature range for the SA1 · · SS series is -20°C (-4°F) to $+70^{\circ}\text{C}$ ($+158^{\circ}\text{F}$), but for the other series, the temperature range is -50°C (-58°F) to $+150^{\circ}\text{C}$ ($+302^{\circ}\text{F}$).

2. Tolerances of Spherical Plain Bearings

Definitions.

The symbols used in the tolerance table are defined as follows;

Symbols

- d = bearing bore diameter, nominal
- Δd_{mp} = single plane mean bore diameter deviation
- Vd_p = bore diameter variation in a single radial plane
- Vd_{mp} = mean bore diameter variation
- ΔB_s = deviation of a single width of the inner ring
- D = bearing outside diameter, nominal
- ΔD_{mp} = single plane mean outside diameter deviation
- VD_p = outside diameter variation in a single radial plane
- VD_{mp} = mean outside diameter variation
- ΔC_s = deviation of a single width of the outer ring
- ΔT_s = deviation of mean height of thrust spherical plain bearings

Table 1 gives the dimensions of oil holes and grooves in the inner rings and the outer rings.

Two equally spaced oil holes are provided.

Four equally spaced oil holes are provided if the nominal bearing outside diameter exceeds 200mm. (7.8740 inch).

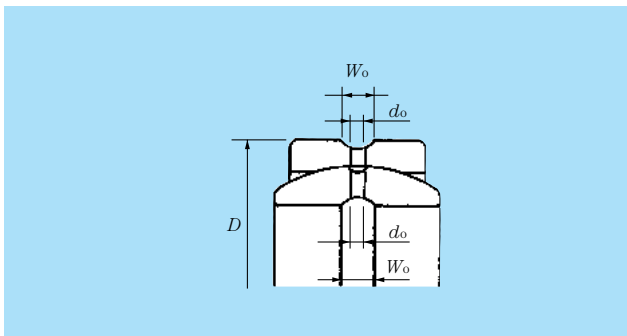

Table 1 Dimensions of lubrication grooves and holes

		D		W_0		d_o	
		inch		inch		inch	
mm		mm	inch	mm	inch	mm	inch
over	incl.	over	incl.	mm	inch	mm	inch
—	30	—	1.1811	2	0.08	1.5	0.06
30	50	1.1811	1.9685	3	0.12	2	0.08
50	65	1.9685	2.5591	4	0.16	2.5	0.10
65	80	2.5591	3.1496	5	0.20	3	0.12
80	120	3.1496	4.7244	7	0.28	4	0.16
120	180	4.7244	7.0866	9	0.35	5	0.20
180	250	7.0866	9.8425	11	0.43	6	0.24
250	400	9.8425	15.7480	13	0.51	8	0.31
400	500	15.7480	19.6850	16	0.63	10	0.39

**Table 2 Tolerance of spherical plain bearings
Inner ring**

<i>d</i>		Δd_{mp}				V_{dp}		V_{dmp}		ΔB_s				ΔT_s			
mm	inch	μm		0.0001 inch		μm	0.0001 inch	μm	0.0001 inch	μm		0.0001 inch		μm		0.0001 inch	
over	incl.	high	low	high	low	max		max		high	low	high	low	high	low	high	low
2.5	10	0	-8	0	-3	8	3	6	2.5	0	-120	0	-47	—	—	—	—
10	18	0	-8	0	-3	8	3	6	2.5	0	-120	0	-47	—	—	—	—
18	30	0	-10	0	-4	10	4	8	3	0	-120	0	-47	+200	-200	+79	-79
30	50	0	-12	0	-4.5	12	4.5	9	3.5	0	-120	0	-47	+200	-200	+79	-79
50	80	0	-15	0	-6	15	6	11	4.5	0	-150	0	-59	+250	-250	+98	-98
80	120	0	-20	0	-8	20	8	15	6	0	-200	0	-79	—	—	—	—
120	180	0	-25	0	-10	25	10	19	7.5	0	-250	0	-98	—	—	—	—
180	250	0	-30	0	-12	30	12	23	9	0	-300	0	-118	—	—	—	—
250	315	0	-35	0	-14	35	14	26	10	0	-350	0	-138	—	—	—	—

Outer ring

<i>D</i>		ΔD_{mp}				V_{Dp}		V_{Dmp}		ΔC_s			
mm	inch	μm		0.0001 inch		μm	0.0001 inch	μm	0.0001 inch	μm		0.0001 inch	
over	incl.	high	low	high	low	max		max		high	low	high	low
10	18	0	-8	0	-3	10	4	6	2.5	0	-240	0	-94
18	30	0	-9	0	-3.5	12	4.5	7	3	0	-240	0	-94
30	50	0	-11	0	-4.5	15	6	8	3	0	-240	0	-94
50	80	0	-13	0	-5	17	6.5	10	4	0	-300	0	-118
80	120	0	-15	0	-6	20	8	11	4.5	0	-400	0	-157
120	150	0	-18	0	-7	24	9.5	14	5.5	0	-500	0	-197
150	180	0	-25	0	-10	33	13	19	7.5	0	-500	0	-197
180	250	0	-30	0	-12	40	16	23	9	0	-600	0	-236
250	315	0	-35	0	-14	47	19	26	10	0	-700	0	-276
315	400	0	-40	0	-16	53	21	30	12	0	-800	0	-315
400	500	0	-45	0	-18	60	24	34	13	0	-900	0	-354

Table 3 Tolerances for chamfer dimensions

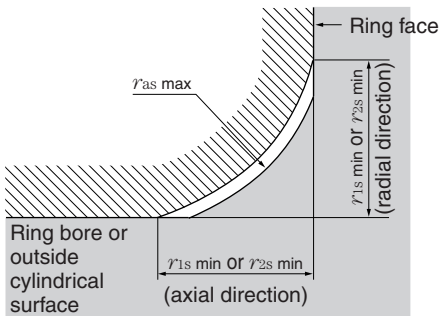

$r_{1s} \text{ min}$ or $r_{2s} \text{ min}$	<i>d</i>				$r_{1s} \text{ max}$ OR $r_{2s} \text{ max}$				(Reference) Shaft or housing fillet radius $r_{as} \text{ max}$		
	mm		inch		radial direction		axial direction				
	over	incl.	over	incl.	mm	inch	mm	inch			
0.3	0.012	—	40	—	1.5748	0.6	0.024	1	0.039	0.3	0.012
		40	—	1.5748	—	0.8	0.031	1	0.039		
0.6	0.024	—	40	1.5748	1.5748	1	0.039	2	0.079	0.6	0.024
		40	—	—	—	1.3	0.051	2	0.079		
1	0.039	—	50	1.9685	1.9685	1.5	0.059	3	0.118	1	0.039
		50	—	—	—	1.9	0.075	3	0.118		
1.1	0.043	—	120	4.7244	4.7244	2	0.079	3.5	0.138	1	0.039
		120	—	—	—	2.5	0.098	4	0.157		

3. Loads Acting on Spherical Plain Bearings

3.1 Equivalent radial load

Loads applying to spherical plain bearings include a radial load, that is, a load acting vertically to the axis of the bearing, and a thrust load which acts parallel to it. Arbitrary directions of the load must be divided into radial and thrust loads, and an equivalent radial load is obtained by the following formula (1):

$$P_r = F_r + YF_a \dots\dots\dots (1)$$

where in

P_r = equivalent radial load, N, lbf

F_r = radial load, N, lbf

F_a = thrust load, N, lbf

Y = axial load factor

Axial load factors Y to be used are shown in Table 4 below.

In the case of the self-lubricating type, however, the thrust load should not exceed the permissible axial loads P_t mentioned in the dimension table.

Table 4 Axial load factor Y

F_a/F_r	0.1	0.2	0.3	0.4	0.5	0.5 <
Bearing types						
Self-lubrication type	1	2	3	Unfit		
Lubrication type	1	2	3	4	5	Unfit

3.2 Fluctuating load

When the magnitude of load applied to the bearing is not constant but is subject to simple periodical fluctuations, an average load can be obtained by the following formula (2):

$$F_m = \frac{F_{min} + 2F_{max}}{3} \dots\dots\dots (2)$$

where

F_m = average load, N, lbf

F_{min} = minimum fluctuating load, N, lbf

F_{max} = maximum fluctuating load, N, lbf

4. Selection of Spherical Plain Bearings

In the selection of NTN spherical plain bearings, the choice of either the self-lubricating type or the lubrication type is determined by the part of the machine where it is to be used, and by operating conditions such as surface pressure, direction in which the load applies, operating temperature, and lubricating conditions.

4.1 Dynamic load and dynamic load rating

Permissible loads for spherical plain bearings against their dynamic load rating vary with their types and with the nature of the loads applying. The limits for these loads are shown in Table 5.

Table 5 Limit loads

Bearing type \ Direction of load	Load acting in one direction	Load acting in a variable direction
Self-lubricating	1 C_d	0.5 C_d
Lubrication type	0.3 C_d	0.6 C_d

In the case of the self-lubricating type, the influence of the operating temperature on the dynamic load rating must be taken into account, using the following formula (3).

$$C_{dt} = f_t \cdot C_d \dots \dots \dots (3)$$

where,

C_{dt} = dynamic load rating with temperature factor considered taken into account, N, lbf

C_d = dynamic load rating, N, lbf
(see the dimensions table)

f_t = temperature factor (see Fig. 1)

4.2 Permissible thrust load

The limit of a thrust load is acting on spherical plain bearings is determined by the ratio of the thrust load F_a and the radial load F_r as follows:

Self-lubricating type bearing:

$$F_a / F_r \leq 0.3$$

Lubrication type bearing:

$$F_a / F_r \leq 0.5$$

In the case of the self-lubricating type bearing, however, the thrust load should not exceed the permissible axial load P_t mentioned in the table of dimensions. Further-more, P_t must be adjusted by a temperature factor f_t , as shown in Fig. 1.

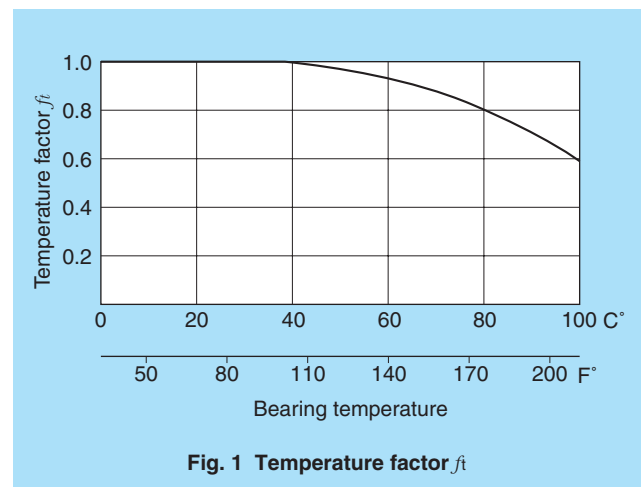

Fig. 1 Temperature factor f_t

4.3 Sliding speed and load

It is recommended that NTN spherical plain bearings be used within the permissible range of values as shown in Fig. 2, for the relationship between the sliding speed V and the load P applied to the bearing. Should you desire to use them beyond this range, please consult NTN.

The sliding speed can be obtained by the following formula (4) :

$$V = 8.7 \times 10^{-6} (d + D) \cdot \theta \cdot f \dots \dots \dots (4)$$

where,

V = sliding speed, m/min, ft/min

d = bore of the bearing, mm, inch

D = O.D. of the bearing, mm, inch

θ = oscillating angle deg.

f = frequency of oscillation cpm

4.4 Static load and load rating

In cases where the load applied to the bearing is static or where the bearing undergoes oscillating movement only at rare intervals, the limiting maximum load applied to the bearing is as shown in Table 6.

Table 6 Limit loads for static use

Bearing type	Permissible load (max)	Remarks
Self-lubricating type	1.5 times C_d	The influence of temperature must be taken into account. (refer to formula (3).)
Lubrication type	1/6 of C_s	For general use.
	1/4 of C_s	Applicable where the frequency of use is very low and the bearing is well lubricated.

C_d = dynamic load rating
 C_s = static load rating

Where a static load close to C_s is applied, it is also necessary to review the strength of the shaft.

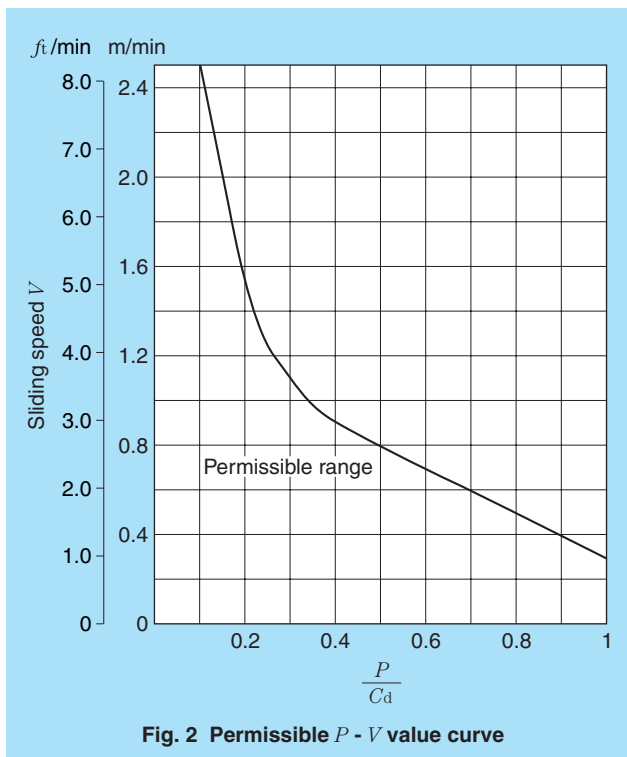

5. Life of Spherical Plain Bearings

5.1 Self-lubricating type bearings

The life of self-lubricating type bearings is determined by the degree of wear of the PTFE based material on the sliding part. The wear progresses in stages, through initial wear, normal wear and abnormal wear. The time of occurrence of abnormal wear is considered as the limit to continuous use of the bearing.

This limit to the continuous use of a bearing is, under conditions of normal wear expressed in terms of the total sliding distance covered before the amount of wear (amount of increase in clearance) reaches a certain limit value.

The total sliding distance S, with the amount of wear taken at 0.1 mm (0.004inch), is shown in Fig. 3. In general use, bearings can be continuously used for two to three (2-3) times the values obtained from this graph.

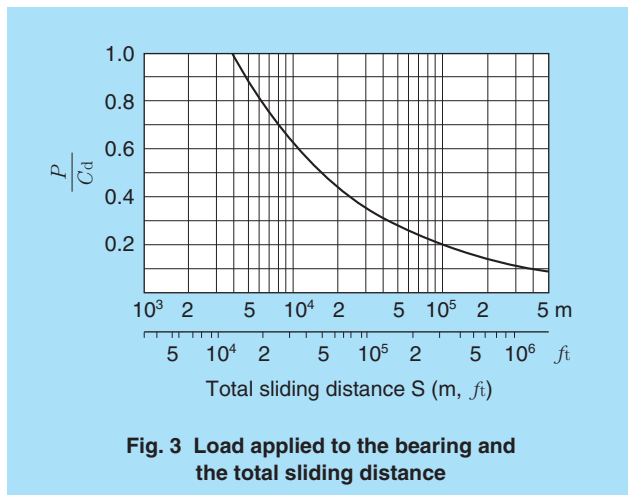

5.2 Lubrication type bearings

The total service life of lubrication type bearings can be obtained from the following formula (5):

$$L_h = \frac{f_w \cdot f_1 \cdot L_1}{60 \cdot f} \dots\dots\dots (5)$$

where,

L_h : total service life h

f_w : lubrication factor

f_1 : factor of load direction

L_1 : initial service life

f : frequency of oscillation cpm

The procedure for this calculation is as follows:

- (1) Sliding speed V from formula (4)
- (2) Speed factor f_n from Fig. 4
- (3) Initial service life L_1 from Fig. 5
- (4) Number of oscillations during the interval of relubrication : Z_w from formula (6)

$$Z_w = 60 \cdot f \cdot H \dots\dots\dots (6)$$

where,

f : frequency of oscillation cpm

H : interval of relubrications h

(5) Lubrication factor f_w from Fig. 6

(6) Factor of load direction f_1from Table 7

Using the values obtained as above, the total service life is to be calculated from formula (5) .

Table 7 Factor of load direction

Load conditions	f_1
Load acting in one direction	1
Load acting in a variable direction	5

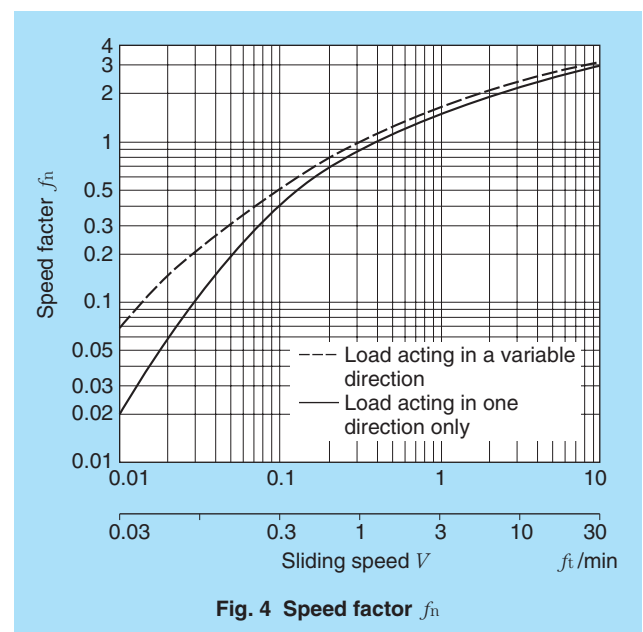

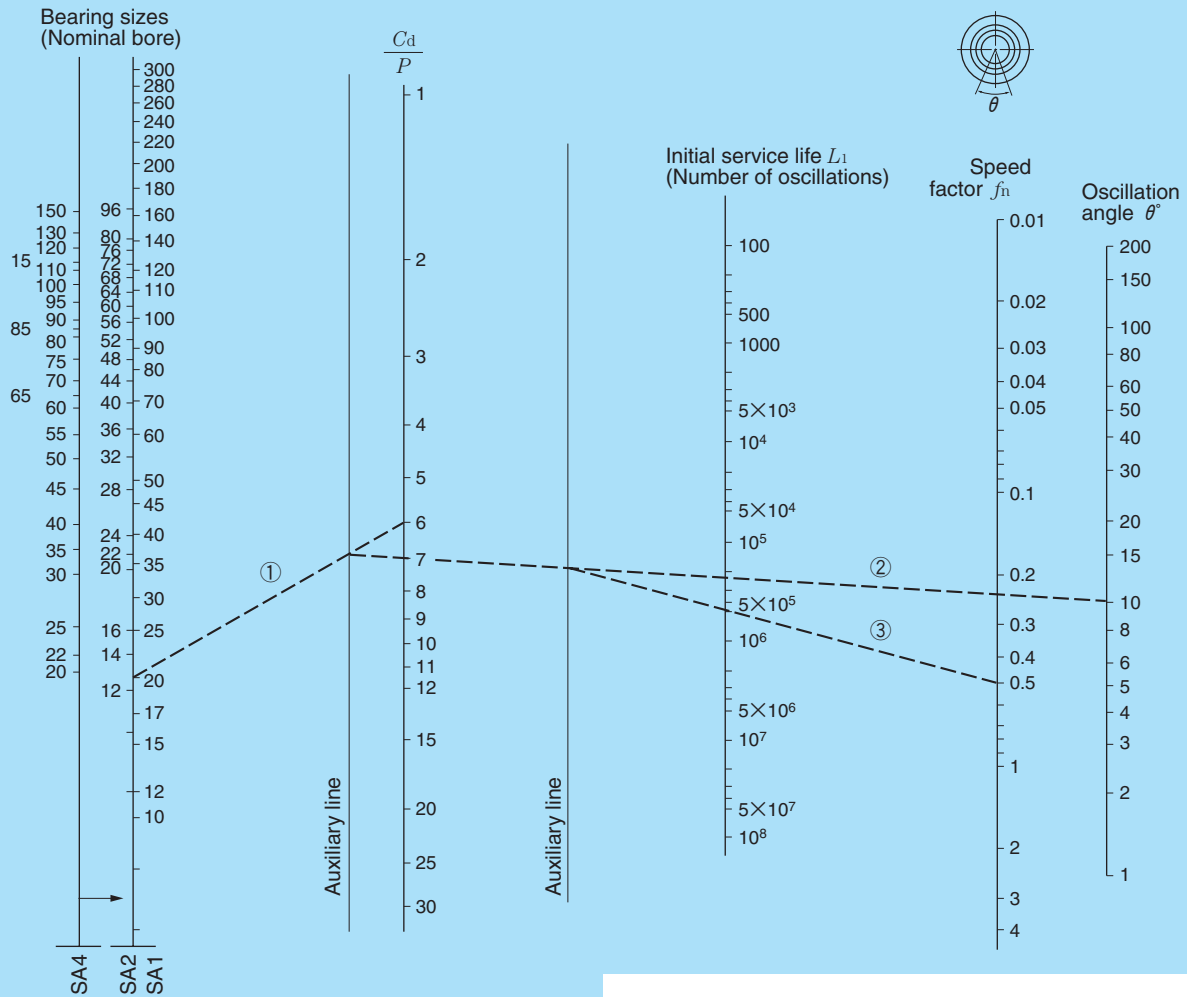

Example: SA1-20B

Load condition $\frac{C_d}{P} = 6$

Oscillation angle $\theta = 10^\circ$

Speed factor $f_n = 0.5$

Initial service life L_1 , in this instance, works out as:

$L_1 = 5 \times 10^5$ times

When a bearing of the SA4 series is used, move the SA4 scale to the position of the SA1 scale, and then connect its size number with its $\frac{C_d}{P}$ value.

Fig. 5 Nomogram of the initial service life L_1 , (Lubrication type bearings)

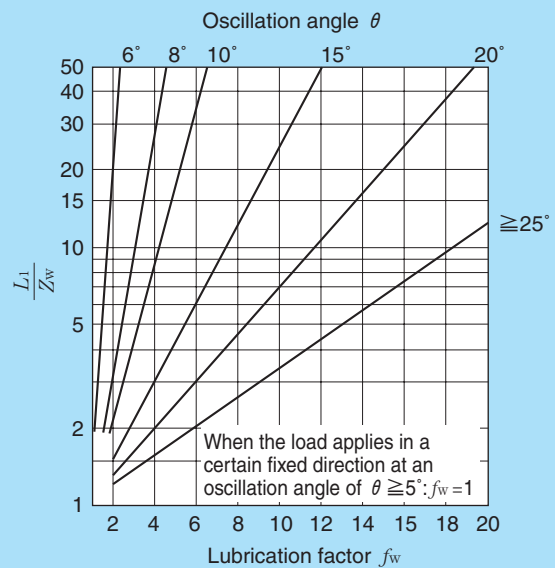

Fig. 6 Lubrication factor f_w

6. Recommended Fit and Internal Clearance

6.1 Recommended fit

The recommended fits for NTN self-lubricating type and lubrication type spherical plain bearings are shown in Tables 8 and 9.

Table 8 Recommended fit for self-lubricating type spherical plain bearings

Operating conditions		Fit		
		Shaft	Housing	
			Steel	Light alloy
Rotating inner ring load	Normal load	k6 ①	H7	J7
	Heavy load	m6 ①		
Rotating outer ring load	Normal load	h6	K7 ②	M7 ②
	Heavy load		M7 ②	—

Notes:

- ① When mounting the bearing, take special care not to apply a large axial load. When it is necessary, for convenience of fitting, to adopt a clearance fit for mounting the bearing on the shaft, fit "h6" or "g6" may be used. In this case the surface of the shaft must be hardened and it is recommended that the fitting surfaces be coated with molybdenum disulphide.
- ② When it is necessary for the bearing to be able to move in the axial direction in the housing, or when the load is light, fit "H7" may be used. In these cases, it is recommended that the fitting surfaces be coated with molybdenum disulphide. Use special care not to let molybdenum disulphide enter into the sliding surface of the bearings.

Table 9 Recommended fit for lubrication type spherical plain bearings

Operating conditions		Fit		
		Shaft	Housing	
			Steel	Light alloy
Rotating inner ring load	Normal load	k6 ①	J7	K7
	Heavy load	m6 ①		
Rotating outer ring load	Normal load	h6 ②	K7	M7
	Heavy load		N7	P7

Notes:

- ① When it is necessary, for convenience of fitting, to adopt a clearance fit for mounting the bearing on the shaft, fit "h6" or "g6" may be used. In this instance, however, the surface of the shaft must be hardened and it is recommended that the fitting surfaces be coated with molybdenum disulphide.
- ② When the sliding speed is high, fit "j6" is recommended.

6.2 Internal bearing clearance

Internal clearance of NTN self-lubricating type and lubrication type spherical plain bearings are shown in Table 10.

Table 10 Internal clearance

Nominal bore <i>d</i>				Self-lubricating type				Lubrication type			
mm		inch		min		max		min		max	
over	incl.	over	incl.	μm	0.0001 inch	μm	0.0001 inch	μm	0.0001 inch	μm	0.0001 inch
6	10	0.2362	0.3937	8	3	32	13	50	20	80	31
10	18	0.3937	0.7087	10	4	40	16	50	20	90	35
18	30	0.7087	1.1811	12	4.5	50	20	60	24	100	39
30	50	1.1811	1.9685	15	6	60	24	70	28	120	47
50	80	1.9685	3.1496	18	7	72	28	80	31	150	59
80	120	3.1496	4.7244	—	—	—	—	100	39	180	71
120	180	4.7244	7.0866	—	—	—	—	120	47	210	83
180	250	7.0866	9.8245	—	—	—	—	170	67	270	106
250	315	9.8425	12.4016	—	—	—	—	200	79	310	122

Notes: Tolerance in inches are converted from the original figures specified in μm and rounded for reference.

7. Cautions to Installation

To install the oil lubricating bearing to the housing, position the bearing so that the cut in the outer ring shall be perpendicular to the load acting direction as illustrated in Fig. 7.

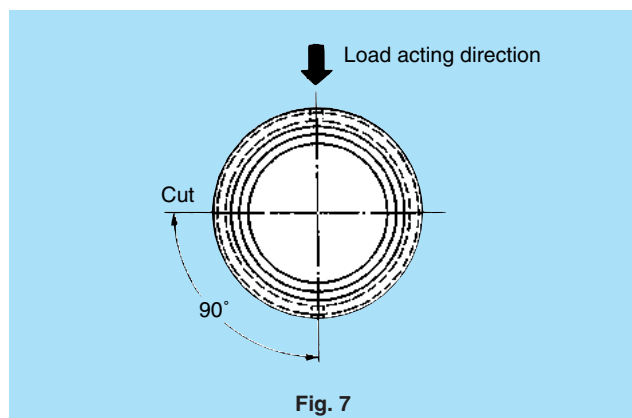
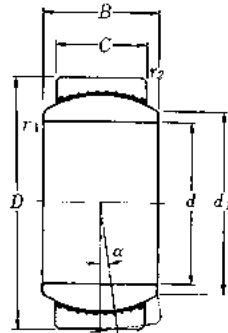

Fig. 7

NTN Spherical Plain Bearings

Self-lubricating type

Series SAR1
SAR1··SS



SAR1
 $d \leq 20\text{mm}$

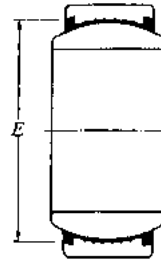

SAR1
 $d \geq 25\text{mm}$

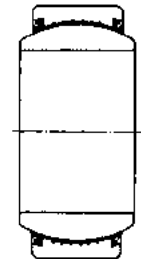

SAR1··SS
with seal

Bearing numbers		Dimensions mm inch								Max. angle of mis- alignment	Dynamic load rating	Limiting thrust load	Mass
SAR1	SAR1··SS	d	D	B	C	r_{1s} min	r_{2s} min	d_1	E	α	C_d N lbf	P_t N lbf	kg lb
SAR1-10	—	10 0.3937	19 0.7480	9 0.3543	6 0.2362	0.6 0.024	0.3 0.012	13.1 0.516	—	12°	8 400 1 890	510 115	0.010 0.022
SAR1-12	—	12 0.4724	22 0.8661	10 0.3937	7 0.2756	0.6 0.024	0.6 0.024	15.3 0.602	—	10°	11 400 2 570	735 165	0.015 0.033
SAR1-15	—	15 0.5906	26 1.0236	12 0.4724	9 0.3543	0.6 0.024	0.6 0.024	18.7 0.736	—	8°	17 300 3 900	1 160 260	0.025 0.055
SAR1-17	—	17 0.6693	30 1.1811	14 0.5512	10 0.3937	0.6 0.024	0.6 0.024	21.2 0.835	—	10°	21 800 4 900	1 360 305	0.040 0.088
SAR1-20	—	20 0.7874	35 1.3780	16 0.6299	12 0.4724	0.6 0.024	0.6 0.024	23.7 0.933	—	9°	26 900 6 050	1 590 355	0.062 0.137
SAR1-25	SAR1-25SS	25 0.9843	42 1.6535	20 0.7874	16 0.6299	0.6 0.024	0.6 0.024	29.3 1.154	37.2 1.465	7°	40 500 9 100	2 290 515	0.102 0.225
SAR1-30	SAR1-30SS	30 1.1811	47 1.8504	22 0.8661	18 0.7087	0.6 0.024	0.6 0.024	34.2 1.346	42 1.654	6°	51 000 11 500	2 640 595	0.138 0.304
SAR1-35	SAR1-35SS	35 1.3780	55 2.1654	25 0.9843	20 0.7874	0.6 0.024	1 0.039	39.8 1.567	48.8 1.921	6°	65 000 14 600	3 050 685	0.220 0.485
SAR1-40	SAR1-40SS	40 1.5748	62 2.4409	28 1.1024	22 0.8661	0.6 0.024	1 0.039	45 1.772	55.2 2.173	7°	81 000 18 300	3 700 830	0.300 0.661
SAR1-45	SAR1-45SS	45 1.7717	68 2.6772	32 1.2598	25 0.9843	0.6 0.024	1 0.039	50.8 2.000	62.4 2.457	7°	106 000 23 800	5 000 1 120	0.400 0.882
SAR1-50	SAR1-50SS	50 1.9685	75 2.9528	35 1.3780	28 1.1024	0.6 0.024	1 0.039	56 2.205	68.4 2.693	6°	124 000 28 000	5 500 1 240	0.530 1.17
SAR1-60	SAR1-60SS	60 2.3622	90 3.5433	44 1.7323	36 1.4173	1 0.039	1 0.039	66.8 2.630	81 3.189	6°	178 000 40 000	7 450 1 670	0.960 2.12

NTN Spherical Plain Bearings

Self-lubricating type

Series SAR4

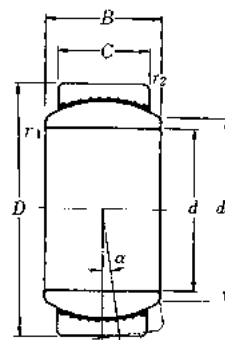

Bearing numbers	Dimensions mm inch							Max. angle of misalignment α	Dynamic load rating		Limiting thrust load		Mass
	<i>d</i>	<i>D</i>	<i>B</i>	<i>C</i>	<i>r</i> _{1s} min	<i>r</i> _{2s} min	<i>d</i> ₁ (Ref.)		<i>C</i> _d	N lbf	<i>P</i> _t	N lbf	kg lb
SAR4-22	22	37	19	16	0.3	0.3	25.7	6°	32 000	1 680	375	0.085	
	0.8661	1.4567	0.7480	0.6299	0.012	0.012	1.012		7 150				0.187
SAR4-25	25	42	21	18	0.3	0.3	29.2	5°	39 000	1 940	435	0.120	
	0.9843	1.6535	0.8268	0.7087	0.012	0.012	1.150		8 800				0.265
SAR4-30	30	50	27	23	0.6	0.6	34.7	6°	54 500	2 330	525	0.222	
	1.1811	1.9685	1.0630	0.9055	0.024	0.024	1.366		12 200				0.489
SAR4-35	35	55	30	26	0.6	0.6	39.4	5°	72 000	3 350	755	0.270	
	1.3780	2.1654	1.1811	1.0236	0.024	0.024	1.511		16 100				0.595
SAR4-40	40	62	33	28	0.6	0.6	44.6	6°	91 000	4 300	965	0.370	
	1.5748	2.4409	1.2992	1.1024	0.024	0.024	1.756		20 400				0.816
SAR4-45	45	72	36	31	0.6	0.6	52.9	5°	117 000	5 150	1 160	0.570	
	1.7717	2.8346	1.4173	1.2205	0.024	0.024	2.083		26 200				1.26
SAR4-50	50	80	42	36	0.6	0.6	58.5	5°	147 000	6 400	1 440	0.820	
	1.9685	3.1496	1.6535	1.4173	0.024	0.024	2.303		33 000				1.81

NTN Spherical Plain Bearings

Self-lubricating type

Series SAR2 (Inch size)

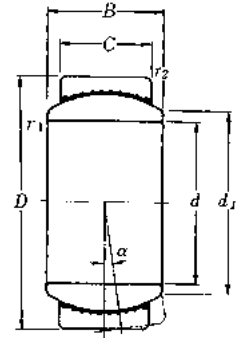

Bearing numbers	Dimensions mm inch							Max. angle of misalignment α	Dynamic load rating		Limiting thrust load		Mass
	<i>d</i>	<i>D</i>	<i>B</i>	<i>C</i>	<i>r</i> _{1s} min	<i>r</i> _{2s} min	<i>d</i> ₁ (Ref.)		<i>C</i> _d	lbf N	<i>P</i> _t	lbf N	lb kg
SAR2-12	0.7500	1.2500	0.656	0.562	0.012	0.024	0.862	6°	5 650	340	0.123		
	19.05	31.75	16.662	14.275	0.3	0.6	21.9		25 200	1 520	0.056		
SAR2-14	0.8750	1.4375	0.765	0.656	0.012	0.024	1.000	6°	7 150	375	0.190		
	22.225	36.512	19.431	16.662	0.3	0.6	25.4		32 000	1 680	0.086		
SAR2-16	1.0000	1.6250	0.875	0.750	0.012	0.024	1.114	6°	8 800	435	0.273		
	25.4	41.275	22.225	19.05	0.3	0.6	28.3		39 000	1 940	0.124		
SAR2-20	1.2500	2.0000	1.093	0.937	0.024	0.024	1.417	6°	12 900	535	0.512		
	31.75	50.8	27.762	23.8	0.6	0.6	36		57 000	2 370	0.232		
SAR2-22	1.3750	2.1875	1.187	1.031	0.024	0.039	1.547	5°	16 100	755	0.763		
	34.925	55.562	30.15	26.187	0.6	1	39.3		72 000	3 350	0.346		
SAR2-24	1.5000	2.4375	1.312	1.125	0.024	0.039	1.622	6°	18 300	830	0.926		
	38.1	61.912	33.325	28.575	0.6	1	41.2		81 000	3 700	0.420		
SAR2-28	1.7500	2.8125	1.531	1.312	0.024	0.039	2.000	6°	25 200	1 030	1.42		
	44.45	71.438	38.887	33.325	0.6	1	50.8		112 000	4 600	0.643		
SAR2-32	2.0000	3.1875	1.750	1.500	0.024	0.039	2.228	6°	29 500	1 030	2.05		
	50.8	80.962	44.45	38.1	0.6	1	56.6		131 000	4 600	0.931		

NTN Spherical Plain Bearings

Lubrication type

Series SA1
SA1··SS

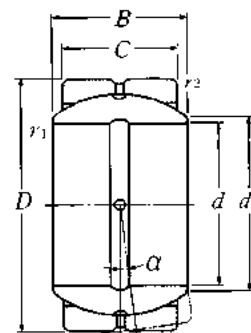

SA1
15mm ≥ d ≥ 140mm

Bearing numbers ①		Dimensions								Max. angle of misalignment α	Dynamic load rating		Static load rating		Mass
		mm		inch		r_{1s} min	r_{2s} min	d_1	E		C_d	N	C_s	N	
SA1	SA1··SS	d	D	B	C			(Ref.)	(Ref.)		lbf		lbf	lb	
SA1-10B ②	—	10 0.3937	19 0.7480	9 0.3543	6 0.2362	0.6 0.024	0.3 0.012	13.1 0.561	—	12°	9 350 2 100		56 000 12 600	0.012 0.026	
SA1-12B ②	—	12 0.4724	22 0.8661	10 0.3937	7 0.2756	0.6 0.024	0.6 0.024	15.3 0.602	—	10°	12 500 2 820		75 000 16 900	0.017 0.037	
SA1-15B	—	15 0.5906	26 1.0236	12 0.4724	9 0.3543	0.6 0.024	0.6 0.024	18.7 0.736	—	8°	19 600 4 400		118 000 26 500	0.032 0.071	
SA1-17B	SA1-17BSS	17 0.6693	30 1.1811	14 0.5512	10 0.3937	0.6 0.024	0.6 0.024	21.2 0.835	25.6 1.008	10°	24 900 5 600		149 000 33 500	0.049 0.108	
SA1-20B	SA1-20BSS	20 0.7874	35 1.3780	16 0.6299	12 0.4724	0.6 0.024	0.6 0.024	23.7 0.933	29.2 1.150	9°	33 500 7 550		202 000 45 500	0.065 0.143	
SA1-25B	SA1-25BSS	25 0.9843	42 1.6535	20 0.7874	16 0.6299	0.6 0.024	0.6 0.024	29.3 1.154	35.5 1.398	7°	55 500 12 500		335 000 75 000	0.115 0.254	
SA1-30B	SA1-30BSS	30 1.1811	47 1.8504	22 0.8661	18 0.7087	0.6 0.024	0.6 0.024	34.2 1.346	40.6 1.598	6°	72 000 16 200		430 000 97 000	0.160 0.353	
SA1-35B	SA1-35BSS	35 1.3780	55 2.1654	25 0.9843	20 0.7874	0.6 0.024	1 0.039	39.8 1.567	46.6 1.835	6°	92 000 20 700		555 000 124 000	0.258 0.569	
SA1-40B	SA1-40BSS	40 1.5748	62 2.4409	28 1.1024	22 0.8661	0.6 0.024	1 0.039	45 1.772	53.5 2.106	7°	114 000 25 700		685 000 154 000	0.315 0.694	
SA1-45B	SA1-45BSS	45 1.7717	68 2.6772	32 1.2598	25 0.9843	0.6 0.024	1 0.039	50.8 2.000	59.9 2.358	7°	147 000 33 000		885 000 198 000	0.413 0.910	
SA1-50B	SA1-50BSS	50 1.9685	75 2.9528	35 1.3780	28 1.1024	0.6 0.024	1 0.039	56 2.205	65.6 2.583	6°	181 000 40 500		1 090 000 244 000	0.560 1.23	
SA1-60B	SA1-60BSS	60 2.3622	90 3.5433	44 1.7323	36 1.4173	1 0.039	1 0.039	66.8 2.630	78.9 3.106	6°	282 000 63 500		1 690 000 380 000	1.10 2.43	
SA1-70B	SA1-70BSS	70 2.7559	105 4.1339	49 1.9291	40 1.5748	1 0.039	1 0.039	77.9 3.067	90.2 3.551	6°	360 000 81 000		2 170 000 485 000	1.54 3.40	
SA1-80B	SA1-80BSS	80 3.1496	120 4.7244	55 2.1654	45 1.7717	1 0.039	1 0.039	89.4 3.520	104.6 4.118	6°	465 000 104 000		2 780 000 625 000	2.29 5.05	

① Bearing number with a suffix "B" designates one-piece outer ring with fractured split. Bearing number without a suffix "B" denotes two-piece outer ring bound with a steel band.

② SA1-10B and SA1-12B no lubricating groove and hole.

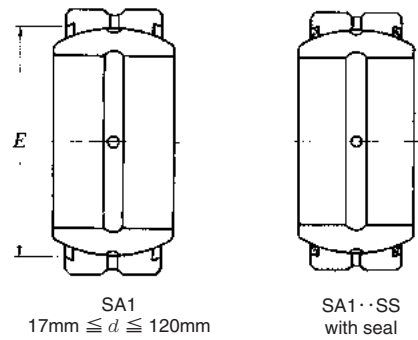

Bearing numbers ^①		Dimensions								Max. angle of misalignment α	Dynamic load rating		Static load rating		Mass
		mm		inch		$r_{1s \text{ min}}$	$r_{2s \text{ min}}$	d_1 (Ref.)	E (Ref.)		C_d	N	lbf	C_s	
SA1	SA1..SS	d	D	B	C					d_1					E
SA1-90B	SA1-90BSS	90 3.5433	130 5.1181	60 2.3622	50 1.9685	1 0.039	1 0.039	98.1 3.862	113.8 4.480	5°	565 000 127 000	3 400 000 760 000	2.82 6.22		
SA1-100B	SA1-100BSS	100 3.9370	150 5.9055	70 2.7559	55 2.1654	1 0.039	1 0.039	109.5 4.311	130.5 5.138	7°	700 000 158 000	4 200 000 945 000	4.43 9.77		
SA1-110B	SA1-110BSS	110 4.3307	160 6.2992	70 2.7559	55 2.1654	1 0.039	1 0.039	121.2 4.772	141.1 5.555	6°	755 000 170 000	4 550 000 1 020 000	4.94 10.9		
SA1-120B	SA1-120BSS	120 4.7244	180 7.0866	85 3.3465	70 2.7559	1 0.039	1 0.039	135.6 5.339	157.3 6.193	6°	1 100 000 247 000	6 600 000 1 480 000	8.12 17.9		
SA1-140	—	140 5.5118	210 8.2677	90 3.5433	70 2.7559	1 0.039	1 0.039	155.9 6.138	—	7°	1 240 000 278 000	7 400 000 1 670 000	11.3 24.9		
SA1-160	—	160 6.2992	230 9.0551	105 4.1339	80 3.1496	1 0.039	1 0.039	170.2 6.701	—	8°	1 570 000 355 000	9 400 000 2 120 000	14.4 31.7		
SA1-180	—	180 7.0866	260 10.2362	105 4.1339	80 3.1496	1.1 0.043	1.1 0.043	199 7.835	—	6°	1 770 000 395 000	10 600 000 2 380 000	18.9 41.7		
SA1-200	—	200 7.8740	290 11.4173	130 5.1181	100 3.9370	1.1 0.043	1.1 0.043	213.5 8.405	—	7°	2 450 000 550 000	14 700 000 3 300 000	28.1 61.9		
SA1-220	—	220 8.6614	320 12.5984	135 5.3150	100 3.9370	1.1 0.043	1.1 0.043	239.6 9.433	—	8°	2 700 000 605 000	16 200 000 3 650 000	36.1 79.6		
SA1-240	—	240 9.4488	340 13.3858	140 5.5118	100 3.9370	1.1 0.043	1.1 0.043	265.3 10.445	—	8°	2 940 000 660 000	17 700 000 3 950 000	40.4 89.1		
SA1-260	—	260 10.2362	370 14.5669	150 5.9055	110 4.3307	1.1 0.043	1.1 0.043	288.3 11.350	—	7°	3 500 000 790 000	21 000 000 4 750 000	52.0 115		
SA1-280	—	280 11.0236	400 15.7480	155 6.1024	120 4.7244	1.1 0.043	1.1 0.043	313.8 12.354	—	6°	4 100 000 925 000	24 700 000 5 550 000	66.0 146		
SA1-300	—	300 11.8110	430 16.9291	165 6.4961	120 4.7244	1.1 0.043	1.1 0.043	336.7 13.256	—	7°	4 400 000 990 000	26 500 000 5 950 000	75.9 167		

① Bearing numbers with a suffix "B" designates one-piece outer ring with fractured split. Bearing numbers without a suffix "B" denotes two-piece outer ring bound with a steel band.

NTN Spherical Plain Bearings

Lubricating type

Series SA4

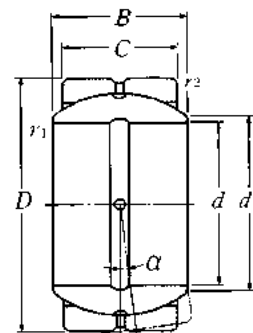

Bearing ^① numbers	Dimensions mm inch							Max. angle of mis- alignment α	Dynamic load rating		Static load rating		Mass
	<i>d</i>	<i>D</i>	<i>B</i>	<i>C</i>	<i>r</i> _{1s} min	<i>r</i> _{2s} min	<i>d</i> ₁ (Ref.)		<i>C</i> _d	N lbf	<i>C</i> _s	N lbf	kg lb
SA4-20B	20 0.7874	32 1.2598	16 0.6299	14 0.5512	0.3 0.012	0.3 0.012	23.6 0.929	4°	39 000 8 800	235 000 53 000	0.050 0.110		
SA4-22B	22 0.8661	37 1.4567	19 0.7480	16 0.6299	0.3 0.012	0.3 0.012	25.7 1.012	6°	50 000 11 300	300 000 67 500	0.085 0.187		
SA4-25B	25 0.9843	42 1.6535	21 0.8268	18 0.7087	0.3 0.012	0.3 0.012	29.2 1.150	5°	63 500 14 300	380 000 85 500	0.116 0.256		
SA4-30B	30 1.1811	50 1.9685	27 1.0630	23 0.9055	0.6 0.024	0.6 0.024	34.7 1.366	6°	99 000 22 300	595 000 134 000	0.225 0.496		
SA4-35B	35 1.3780	55 2.1654	30 1.1811	26 1.0236	0.6 0.024	0.6 0.024	39.4 1.552	5°	126 000 28 400	755 000 170 000	0.300 0.661		
SA4-40B	40 1.5748	62 2.4409	33 1.2992	28 1.1024	0.6 0.024	0.6 0.024	44.6 1.756	6°	152 000 34 500	915 000 206 000	0.373 0.822		
SA4-45B	45 1.7717	72 2.8346	36 1.4173	31 1.2205	0.6 0.024	0.6 0.024	52.9 2.083	5°	195 000 43 500	1 170 000 262 000	0.600 1.32		
SA4-50B	50 1.9685	80 3.1496	42 1.6535	36 1.4173	0.6 0.024	0.6 0.024	58.5 2.303	5°	254 000 57 000	1 530 000 345 000	0.870 1.92		
SA4-55B	55 2.1654	90 3.5433	47 1.8504	40 1.5748	0.6 0.024	0.6 0.024	64.7 2.547	5°	315 000 70 500	1 880 000 425 000	1.25 2.76		
SA4-60B	60 2.3622	100 3.9370	53 2.0866	45 1.7717	0.6 0.024	0.6 0.024	72.7 2.862	6°	395 000 89 500	2 380 000 535 000	1.70 3.75		
SA4-65B	65 2.5591	105 4.1339	55 2.1654	47 1.8504	0.6 0.024	0.6 0.024	76.2 3.000	5°	435 000 97 500	2 600 000 585 000	2.05 4.52		
SA4-70B	70 2.7559	110 4.3307	58 2.2835	50 1.9685	0.6 0.024	0.6 0.024	81.5 3.209	5°	490 000 110 000	2 940 000 660 000	2.22 4.89		

① Bearing numbers with a suffix "B" designates one-piece outer ring with fractured split. Bearing numbers without a suffix "B" denotes two-piece outer ring bound with a steel band.

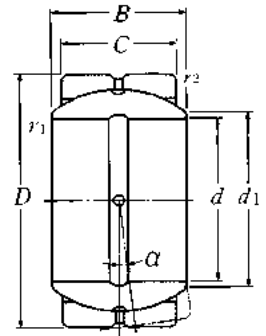

Bearing ① numbers	Dimensions mm inch							Max. angle of mis- alignment α	Dynamic load rating		Static load rating		Mass
	<i>d</i>	<i>D</i>	<i>B</i>	<i>C</i>	<i>r</i> _{1s} min	<i>r</i> _{2s} min	<i>d</i> ₁ (Ref.)		<i>C</i> _d	N	<i>C</i> _s	N	kg
									lbf		lbf	lb	
SA4-75B	75	120	64	55	0.6	0.6	89.5	5°	595 000	3 550 000	800 000	3.02	
	2.9528	4.7244	2.5197	2.1654	0.024	0.024	3.524		133 000				6.66
SA4-80B	80	130	70	60	0.6	0.6	97.5	5°	705 000	4 250 000	950 000	3.98	
	3.1496	5.1181	2.7559	2.3622	0.024	0.024	3.839		159 000				8.77
SA4-85B	85	135	74	63	0.6	0.6	100.7	6°	770 000	4 650 000	1 040 000	4.28	
	3.3465	5.3150	2.9134	2.4803	0.024	0.024	3.965		174 000				9.44
SA4-90B	90	140	76	65	0.6	0.6	105.5	5°	830 000	4 950 000	1 120 000	4.71	
	3.5433	5.5118	2.9921	2.5591	0.024	0.024	4.154		186 000				10.4
SA4-95B	95	150	82	70	0.6	0.6	113.5	5°	960 000	5 750 000	1 300 000	6.05	
	3.7402	5.9055	3.2283	2.7559	0.024	0.024	4.468		216 000				13.3
SA4-100B	100	160	88	75	1	1	121.5	5°	1 100 000	6 600 000	1 490 000	7.42	
	3.9370	6.2992	3.4646	2.9528	0.039	0.039	4.783		248 000				16.4
SA4-110B	110	170	93	80	1	1	130.2	5°	1 260 000	7 550 000	1 690 000	8.50	
	4.3307	6.6929	3.6614	3.1496	0.039	0.039	5.126		282 000				18.7
SA4-115B	115	180	98	85	1	1	132.7	5°	1 380 000	8 250 000	1 860 000	10.3	
	4.5276	7.0866	3.8583	3.3465	0.039	0.039	5.224		310 000				22.7
SA4-120B	120	190	105	90	1	1	140	5°	1 540 000	9 250 000	2 080 000	12.3	
	4.7244	7.4803	4.1339	3.5433	0.039	0.039	5.512		345 000				27.1
SA4-130B	130	200	110	95	1	1	148.7	5°	1 720 000	10 300 000	2 320 000	13.8	
	5.1181	7.8740	4.3307	3.7402	0.039	0.039	5.854		385 000				30.4
SA4-150	150	220	120	105	1	1	166.2	5°	2 110 000	12 700 000	2 850 000	17.0	
	5.9055	8.6614	4.7244	4.1339	0.039	0.039	6.543		475 000				37.5

① Bearing numbers with a suffix "B" designates one-piece outer ring with fractured split. Bearing numbers without a suffix "B" denotes two-piece outer ring bound with a steel band.

NTN Spherical Plain Bearings

Lubrication type

Series SA2 (Inch size)

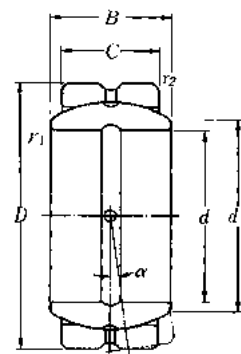

Bearing ^① numbers	Dimensions mm inch							Max. angle of mis- alignment α	Dynamic load rating		Static load rating		Mass lb kg
	<i>d</i>	<i>D</i>	<i>B</i>	<i>C</i>	<i>r</i> _{1s} min	<i>r</i> _{2s} min	<i>d</i> ₁ (Ref.)		<i>C</i> _d	lbf N	<i>C</i> _s	lbf N	
SA2-12B	0.7500	1.2500	0.656	0.562	0.012	0.024	0.862	6°	8 650	52 000	0.123		
	19.05	31.75	16.662	14.275	0.3	0.6	21.9		38 500	231 000		0.056	
SA2-14B	0.8750	1.4375	0.765	0.656	0.012	0.024	1.000	6°	11 800	70 500	0.190		
	22.225	36.512	19.431	16.662	0.3	0.6	25.4		52 500	315 000		0.086	
SA2-16B	1.0000	1.6250	0.875	0.750	0.012	0.024	1.114	6°	15 100	90 500	0.273		
	25.4	41.275	22.225	19.05	0.3	0.6	28.3		67 500	405 000		0.124	
SA2-20B	1.2500	2.0000	1.093	0.937	0.024	0.024	1.417	6°	23 900	143 000	0.511		
	31.75	50.8	27.762	23.8	0.6	0.6	36		106 000	635 000		0.232	
SA2-22B	1.3750	2.1875	1.187	1.031	0.024	0.039	1.547	5°	28 600	171 000	0.763		
	34.925	55.562	30.15	26.187	0.6	1	39.3		127 000	765 000		0.346	
SA2-24B	1.5000	2.4375	1.312	1.125	0.024	0.039	1.622	6°	33 500	200 000	0.926		
	38.1	61.912	33.325	28.575	0.6	1	41.2		149 000	890 000		0.420	
SA2-28B	1.7500	2.8125	1.531	1.312	0.024	0.039	2.000	6°	47 000	282 000	1.42		
	44.45	71.438	38.887	33.325	0.6	1	50.8		209 000	1 250 000		0.643	
SA2-32B	2.0000	3.1875	1.750	1.500	0.024	0.039	2.228	6°	60 500	365 000	2.05		
	50.8	80.962	44.45	38.1	0.6	1	56.6		269 000	1 610 000		0.931	
SA2-36B	2.2500	3.5625	1.969	1.687	0.024	0.039	2.559	6°	77 500	465 000	2.89		
	57.15	90.488	50.013	42.85	0.6	1	65		345 000	2 070 000		1.31	
SA2-40B	2.5000	3.9375	2.187	1.875	0.039	0.039	2.886	5°	96 500	580 000	4.06		
	63.5	100.012	55.55	47.625	1	1	73.3		430 000	2 580 000		1.84	
SA2-44B	2.7500	4.3750	2.406	2.062	0.039	0.039	3.118	6°	115 000	695 000	5.34		
	69.85	111.125	61.112	52.375	1	1	79.2		515 000	3 100 000		2.42	
SA2-48B	3.0000	4.7500	2.625	2.250	0.039	0.039	3.421	6°	138 000	830 000	6.81		
	76.2	120.65	66.675	57.15	1	1	86.9		615 000	3 700 000		3.09	

① Bearing numbers with a suffix "B" designates one-piece outer ring with fractured split. Bearing numbers without a suffix "B" denotes two-piece outer ring bound with a steel band.

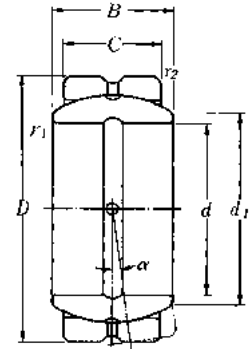

Bearing ^① numbers	Dimensions mm inch							Max. angle of misa- lignment α	Dynamic load rating		Static load rating		Mass	
	<i>d</i>	<i>D</i>	<i>B</i>	<i>C</i>	<i>r</i> _{1s} min	<i>r</i> _{2s} min	<i>d</i> ₁ (Ref.)		<i>C</i> _d	lbf N	<i>C</i> _s	lbf N	lb kg	
SA2-52B	3.2500	5.1250	2.844	2.437	0.039	0.039	3.724	6°	162 000	975 000	8.55			
	82.55	130.175	72.238	61.9	1	1	94.6		720 000	4 350 000	3.88			
SA2-56B	3.5000	5.5000	3.062	2.625	0.039	0.039	4.004	6°	188 000	1 130 000	10.6			
	88.9	139.7	77.775	66.675	1	1	101.7		835 000	5 000 000	4.79			
SA2-60B	3.7500	5.8750	3.281	2.812	0.039	0.039	4.280	6°	216 000	1 290 000	12.9			
	95.25	149.225	83.337	71.425	1	1	108.7		960 000	5 750 000	5.83			
SA2-64B	4.0000	6.2500	3.500	3.000	0.039	0.039	4.559	6°	245 000	1 470 000	15.5			
	101.6	158.75	88.9	76.2	1	1	115.8		1 090 000	6 550 000	7.01			
SA2-68B	4.2500	6.6250	3.719	3.187	0.039	0.039	4.839	6°	277 000	1 660 000	18.5			
	107.95	168.275	94.463	80.95	1	1	122.9		1 230 000	7 400 000	8.39			
SA2-72B	4.5000	7.0000	3.937	3.375	0.039	0.039	5.142	6°	310 000	1 870 000	21.7			
	114.3	177.8	100	85.725	1	1	130.6		1 380 000	8 300 000	9.86			
SA2-76B	4.7500	7.3750	4.156	3.562	0.039	0.039	5.421	6°	345 000	2 080 000	25.4			
	120.65	187.325	105.562	90.475	1	1	137.7		1 540 000	9 250 000	11.5			
SA2-80B	5.0000	7.7500	4.375	3.750	0.039	0.039	5.724	6°	385 000	2 310 000	29.5			
	127	196.85	111.125	95.25	1	1	145.4		1 710 000	10 300 000	13.4			
SA2-96	6.0000	8.7500	4.750	4.125	0.039	0.039	6.622	5°	480 000	2 870 000	38.4			
	152.4	222.25	120.65	104.775	1	1	168.2		2 130 000	12 800 000	17.4			

① Bearing number with a suffix "B" designates one-piece outer ring with fractured split. Bearing number without a suffix "B" denotes two-piece outer ring bound with a steel band.

NTN Thrust Spherical Plain Bearings

Lubrication type

Series SAT

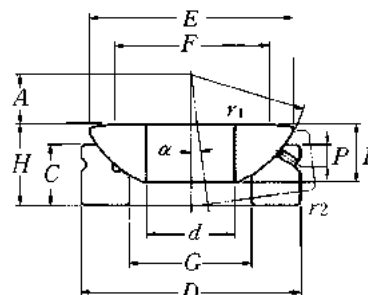

Bearing numbers	Dimensions mm inch												Max. angle of misalignment α	Dynamic load rating C_d N lbf	Static load rating C_s N lbf	Mass kg lb
	<i>d</i>	<i>D</i>	<i>H</i>	<i>B</i>	<i>C</i>	<i>r</i> _{1s} min	<i>r</i> _{2s} min	<i>E</i>	<i>F</i>	<i>G</i>	<i>P</i>	<i>A</i>				
SAT20	20	55	20	14.3	13	0.6	1	50	40	33.5	6	12.5	6°	74 000	445 000	0.260
	0.7874	2.1654	0.7874	0.563	0.512	0.024	0.039	1.969	1.575	1.319	0.236	0.492		16 600	99 500	0.573
SAT25	25	62	22.5	16	17	0.6	1	57.5	45	34.5	6	14	6°	127 000	760 000	0.375
	0.9843	2.4409	0.8858	0.630	0.669	0.024	0.039	2.264	1.772	1.358	0.236	0.551		28 600	171 000	0.827
SAT30	30	75	26	18	19.5	0.6	1	69	56	44	8	17.5	5°	167 000	1 000 000	0.640
	1.1811	2.9528	1.0236	0.709	0.768	0.024	0.039	2.717	2.205	1.732	0.315	0.689		37 500	225 000	1.41
SAT35	35	90	28	22	20	0.6	1	84	66	52	8	22	5°	254 000	1 520 000	1.02
	1.3780	3.5433	1.1024	0.866	0.787	0.024	0.039	3.307	2.598	2.047	0.315	0.866		57 000	345 000	2.25
SAT40	40	105	32	27	22	0.6	1	98	78	59	9	24.5	5°	365 000	2 200 000	1.64
	1.5748	4.1339	1.2598	1.063	0.866	0.024	0.039	3.858	3.071	2.323	0.354	0.965		82 500	495 000	3.62
SAT45	45	120	36.5	31	25	0.6	1	112	89	68	11	27.5	5°	475 000	2 860 000	2.50
	1.7717	4.7244	1.4370	1.220	0.984	0.024	0.039	4.409	3.504	2.677	0.433	1.083		107 000	645 000	5.51
SAT50	50	130	42.5	33.5	32	0.6	1	122.5	98	69	10	30	4°	640 000	3 850 000	3.38
	1.9685	5.1181	1.6732	1.319	1.260	0.024	0.039	4.823	3.858	2.717	0.394	1.181		144 000	860 000	7.45
SAT60	60	150	45	37	33	1	1	140	108	86	12.5	35	6°	720 000	4 350 000	4.62
	2.3622	5.9055	1.7717	1.457	1.299	0.039	0.039	5.512	4.252	3.386	0.492	1.378		162 000	975 000	10.2
SAT70	70	160	50	40	36	1	1	149.5	121.5	95	13.5	35	5°	790 000	4 750 000	5.60
	2.7559	6.2992	1.9685	1.575	1.417	0.039	0.039	5.886	4.783	3.740	0.531	1.378		178 000	1 070 000	12.3
SAT80	80	180	50	42	36	1	1	168	130	108	14.5	42.5	4°	1 020 000	6 100 000	7.12
	3.1496	7.0866	1.9685	1.654	1.417	0.039	0.039	6.614	5.118	4.252	0.571	1.673		229 000	1 370 000	15.7